



No. 3 1977

issued quarterly

Technical Review

To Advance Techniques in Acoustical, Electrical and Mechanical Measurement

Microphones used as Sound Sources

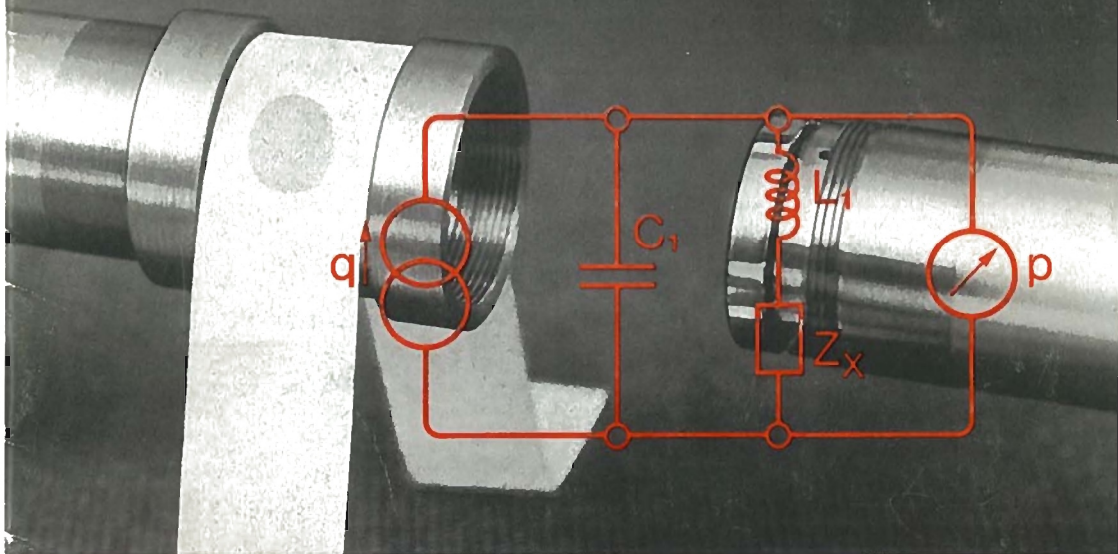

Brüel & Kjær

**PREVIOUSLY ISSUED NUMBERS OF
BRÜEL & KJÆR TECHNICAL REVIEW**

- 2-1977 Automated Measurements of Reverberation Time using the Digital Frequency Analyzer Type 2131.
Measurement of Elastic Modulus and Loss Factor of PVC at High Frequencies.
- 1-1977 Digital Filters in Acoustic Analysis Systems.
An Objective Comparison of Analog and Digital Methods of Real-Time Frequency Analysis.
- 4-1976 An Easy and Accurate Method of Sound Power Measurements.
Measurement of Sound Absorption of rooms using a Reference Sound Source.
- 3-1976 Registration of Voice Quality.
Acoustic Response Measurements and Standards for Motion-Picture Theatres.
- 2-1976 Free-Field Response of Sound Level Meters.
High Frequency Testing of Gramophone Cartridges using an Accelerometer.
- 1-1976 Do We Measure Damaging Noise Correctly?
- 4-1975 On the Measurement of Frequency Response Functions.
- 3-1975 On the Averaging Time of RMS Measurements (continuation).
- 2-1975 On the Averaging Time of RMS Measurements
Averaging Time of Level Recorder Type 2306 and "Fast" and "Slow" Response of Level Recorders 2305/06/07
- 1-1975 Problems in Telephone Measurements.
Proposals for the Measurement of Loudness Ratings of Operators' Headsets.
Comparison of Results obtained by Subjective Measuring Methods.
Repeatabilities in Electro-Acoustic Measurements on Telephone Capsules.
Stable Subset Measurements with the 73 D
Vibration Testing of Telephone Equipment.
- 4-1974 Underwater Impulse Measurements.
A Comparison of ISO and OSHA Noise Dose Measurements.
Sound Radiation from Loudspeaker System with the Symmetry of the Platonic Solids.
- 3-1974 Acoustical Investigation of an Impact Drill.
Measurement of the Dynamic Mass of the Hand-arm System.

(Continued on cover page 3)

TECHNICAL REVIEW

No. 3 — 1977

Contents

Condenser Microphones used as Sound Sources	
by E. Frederiksen	3
News from the Factory	24

Condenser Microphones used as Sound Sources

by

Erling Frederiksen

ABSTRACT

Microphones being reciprocal transducers can be used advantageously as sound sources. In this article it is shown how the sound pressure levels generated by the microphones, can be calculated when they are used in a free-field and under pressure conditions. A typical example illustrates the use of a microphone as a transmitter in determining the acoustical damping properties of a strip of fibre material. Practical precautions to be taken in using microphones as sound sources are also given.

SOMMAIRE

Les microphones étant des transducteurs réciproques, ils peuvent être avantageusement utilisés comme source acoustique. Dans cet article, on montrera comment les niveaux de pression sonore produits par les microphones pourront être calculés lorsque ceux-ci seront utilisés en champ libre et en pression. Un exemple typique illustre l'utilisation d'un microphone comme émetteur dans le cas de la détermination des propriétés d'atténuation acoustique d'une bande de matériau fibreux. Les précautions pratiques que l'on devra prendre pour utiliser les microphones comme source acoustique sont également évoquées ici.

ZUSAMMENFASSUNG

Mikrofone, die umkehrbare Wandler sind, können mit Vorteil als Schallquellen verwendet werden. In diesem Artikel wird gezeigt, wie der von den Mikrofonen erzeugte Schalldruckpegel errechnet werden kann, wenn sie unter Freifeld oder Druckbedingungen arbeiten. Ein typisches Beispiel veranschaulicht die Verwendung eines Mikrofons als Schallsender zur Ermittlung der akustischen Dämpfungseigenschaften eines Fiberstreifens. Daneben werden praktische Vorsichtsmaßnahmen, die bei der Verwendung von Mikrofonen als Schallsender beachtet werden müssen, angegeben.

Introduction

Condenser microphones, being reciprocal transducers, can not only be used as receivers, but also as sound sources. They have the same well-defined properties when used as transmitters as when they are used as receivers. This fact has been known for years and use has been made of it for reciprocity calibration of standard microphones. Under carefully controlled conditions, the calibration accuracy achievable by this method is better than 0,05 dB, which endorses the suitability of microphones for use as sound sources. Although the sound pressure levels

generated are relatively low, they would be sufficient for many practical applications. Furthermore slave filters may be used for obtaining gliding frequency response over a wide range suppressing the background acoustic and electrical noise.

Typical fields of application are:

Hearing experiments with animals and human beings,

Reduced scale experiments for examination of sound propagation (e.g. in architectural acoustics and in town planning),

Acoustic impedance measurements in telephone sets, hearing aids, etc.,

Full or reduced scale experiments for evaluation of complex sound systems (e.g. mufflers, loudspeaker cabinets, etc.),

Testing of acoustic materials,

Calibration of other types of microphones, studio microphones, etc.

The fields of application fall into two main groups of acoustical conditions:

1. free-field conditions, i.e. conditions for which the sound pressure is inversely proportional to the distance from the source
2. pressure-field conditions, i.e. conditions in which the dimensions of the system (being small) prevent wave motion from taking place.

In the following, it is shown how the sound pressure levels generated in the two conditions by a microphone can be determined using the specifications given for the individual microphones.

Free-field Conditions

Using the reciprocity theorem, the modulus of the sound pressure generated at a certain distance from the microphone under free-field conditions can be determined from the formula

$$p = \frac{\rho_0 f M_f i}{2d}$$

where ρ_o = density of air ($1,2 \text{ kg/m}^3$ at 20°C and 1013 mbar)
 f = frequency (Hz)
 i = current input to the microphone (A)
 M_f = free field sensitivity (V/Pa). For axial direction its value may be found on the individual calibration chart. (See page 17)
 d = distance from source microphone

The distance d should actually be measured from the acoustical centre of the transmitting microphone; however, for most practical purposes the geometric centre of the microphone diaphragm may be used, as the maximum error for axial direction would be less than 6 mm for 1'' microphone, 3 mm for 1/2'' microphone and so on. If transmission loss occurs in the media it should be taken into consideration.

As a condenser microphone cartridge has a relatively high impedance (i.e. low electrical capacitance) it is difficult to control the current applied to the microphone on account of stray capacitances. It is therefore more practical to apply a fixed voltage across the terminals of the microphone and determine the sound pressure by substituting in the above equation

$$i = \frac{e}{Z} \approx j\omega C e$$

where C is the electrical capacitance of the microphone.

We therefore obtain

$$p \approx \frac{\pi \rho_o f^2 M_f e C}{d} \quad (1)$$

Using typical values of M_f and C for the individual microphones, the theoretical sound pressure levels generated at a distance of 1 m in front of the microphones are calculated against frequency and shown in Fig.1.

Practical measurements were also carried out in an Anechoic chamber where the same types of microphones were used for the receiver as for the transmitter. The results are shown in Figs.2 — 5 for microphones 4133, 4135, 4145 and 4165.

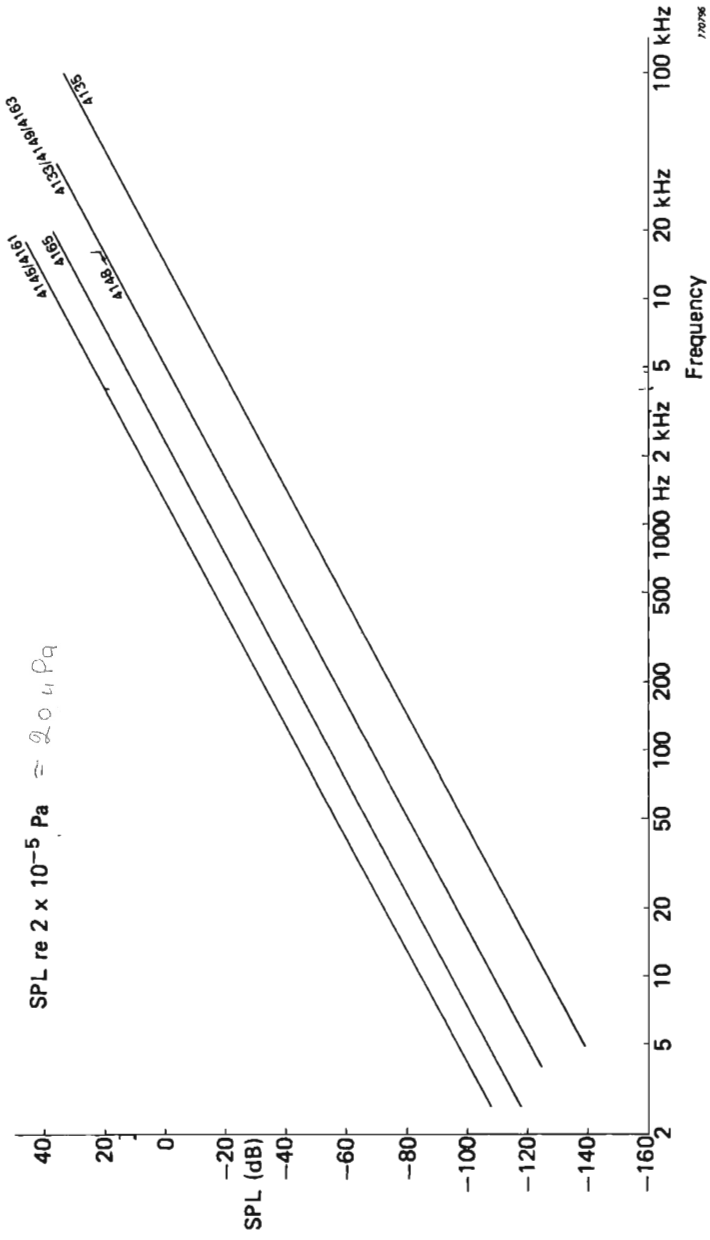

Fig. 1. Theoretical sound pressure levels generated at 1 m distance for 1 Volt input as a function of frequency

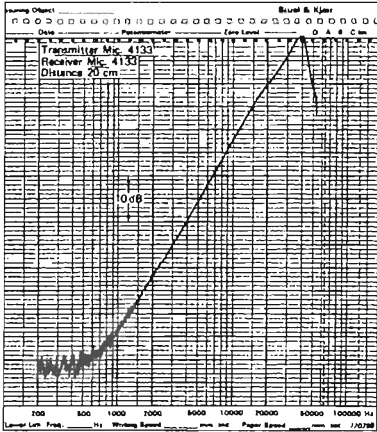

Fig. 2.

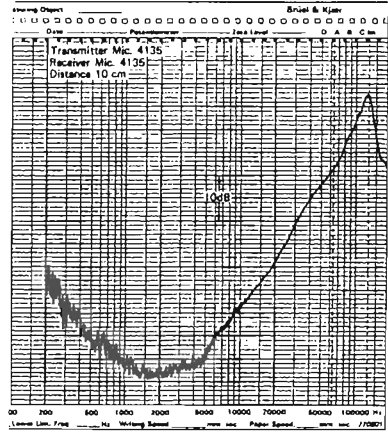

Fig. 3.

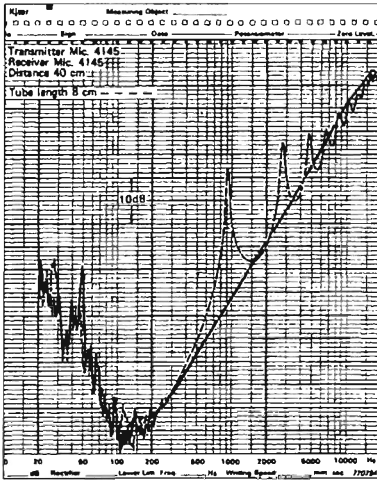

Fig. 4.

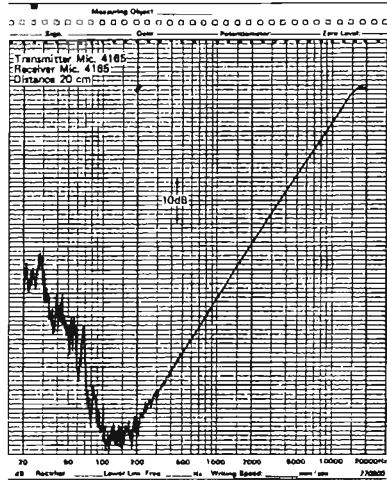

Fig. 5.

Fig. 2—5. Relative sound pressure levels generated under practical conditions by different microphones

From the figures it can be seen that for constant M_f the slope of the curves is 40 dB/decade as it should be according to equation (1). However, at the upper end of the frequency range the slopes can be seen to deviate slightly. This is partly due to non-linear frequency response of the microphones and partly due to the variation of microphone capacitance C with frequency. Corrections for this can be carried out, if necessary. Here, use can be made of typical curves of variation of capacitance with frequency given in the B & K microphone handbook.

Most microphone cartridges have constant sensitivity M_f approximately up to the diaphragm resonance frequency. Above this frequency the diaphragm is mass controlled causing a 40 dB/decade decay. Thus one would expect the response of the transmitting microphone to be flat in this frequency region. However, this is not the case for two reasons. Firstly, the protecting grid, being one of the elements that plays a role in controlling the frequency response, will have its own cut-off frequency in the upper end of the specified frequency range, and secondly, there would be some resonances present caused by the standing waves inside the microphone housing. It should be noted that as the response of the receiving microphone decreases above the resonance frequency the curves shown in Fig.2 — 5 fall off sharply.

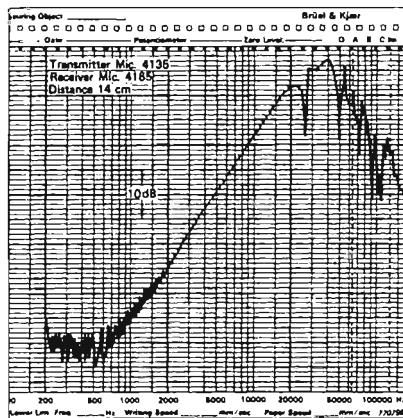

Fig.6. Relative sound pressure levels generated by Microphone Type 4135 but measured by Type 4165

In order to demonstrate the transmission characteristics of 1/4-inch

microphone 4135 at low frequencies, a 1/2-inch microphone Type 4165 was used as a receiver which has a considerably higher sensitivity for obtaining a better signal to noise ratio. The low frequency response of the microphone 4135 is shown in Fig.6. The resonances at the upper end of the frequency range are, of course, those of the receiver microphone 4165.

Under normal circumstances the microphones have a very high impedance relative to the impedance of the media (normally termed the radiation impedance) into which it transmits. In many practical cases this situation is desirable, since the microphone acts as a constant volume velocity source and the radiation impedance has negligible effect on the volume velocity output. In other cases it is desirable to obtain as much emission of power as possible, which can be achieved by a better matching of the impedance of the microphone and the radiation impedance. By mounting a cylindrical tube of length l in front of the microphone cartridge, better impedance matching is possible at fixed frequencies. The length l of the tube can be determined from the formula

$$l = \frac{2n - 1}{4} \lambda$$

where λ is the wavelength of the signal and n is a positive integer.

The dashed curve in Fig.4 shows the transmission characteristics of Microphone Type 4145 when mounted with a cylindrical tube of length 8 cm.

Pressure Conditions

In the appendix it has been shown that the equivalent acoustical circuit of a microphone (at frequencies somewhat lower than the diaphragm resonance frequency) when used as a transmitter, can be reduced to the one illustrated in Fig.7. When an electrical voltage e is applied to the electrical terminals of the microphone, a volume velocity ($M_p e j\omega C$) is applied to the acoustical compliance C_a of the diaphragm and the load impedance Z_L in parallel. The pressure p developed across the load impedance Z_L is given by the equation

$$p = M_p e j\omega C \frac{\frac{1}{j\omega C_a} \cdot Z_L}{\frac{1}{j\omega C_a} + Z_L} \quad (2)$$

where

M_p is the open circuit pressure sensitivity and
 C is the polarized capacity of the microphone quoted on the calibration chart.

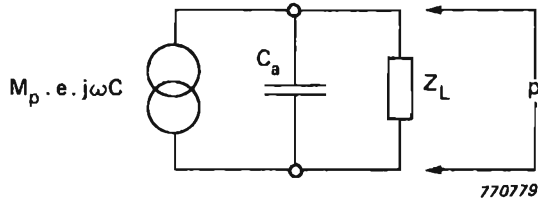

Fig.7. Simplified equivalent circuit of Microphone when connected to a load Z_L

It is now possible to calculate the pressure developed across a known load impedance. It has been done in the following for the cases when it is a) purely capacitive (pure stiffness), b) purely resistive, and c) purely inductive.

a) Acoustical load purely capacitive

An acoustical load presented to the microphone is purely capacitive when the microphone operates, for example, into a cavity of fixed volume V_{cav} . The compliance of such a cavity is given by the equation

$$C_{cav} = \frac{V_{cav}}{\gamma P_a}$$

where $\gamma = \frac{C_p}{C_v}$ the ratio of specific heats (1,402 for air)

and $P_a =$ the static pressure in the cavity

When the microphone is electrically excited, the pressure developed in the cavity can be determined by substituting $1/j\omega C_{cav}$ for Z_L in eq.(2), giving

$$p = M_p e \frac{C}{C_a + C_{cav}}$$

Substituting the cavity volume V_{cav} and equivalent volume of the microphone V_a instead of their respective compliances C_{cav} and C_a we obtain

$$p = M_p e \frac{C \gamma P_a}{V_a + V_{cav}}$$

It can be seen from the equation that the sound pressure generated in the cavity is independent of frequency, in contrast to what is achieved under free-field conditions.

Microphone Type No.	4144	4160	4166	4134	4135	4136	4138
Equivalent Volume V_a in m^3	$0,14 \times 10^{-6}$	$0,14 \times 10^{-8}$	$0,04 \times 10^{-8}$	$0,01 \times 10^{-8}$	$0,60 \times 10^{-9}$	$0,25 \times 10^{-9}$	$< 10^{-10}$
Typical SPL (dB) created in 1 cm^3 volume for 1 V supply to microphones	84,5	84,0	76,7	64,0	45,2	37,2	27,9

Table 1.

In Table 1 the equivalent volumes of different types of microphones are given as well as the typical sound pressure levels that would be generated in a cavity of 1 cm^3 when 1 volt is applied across the microphone terminals.

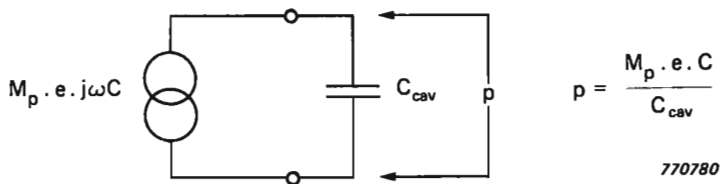

Fig. 8. Further simplified equivalent circuit of microphone when connected to a purely capacitive load

From the table it can be seen that the equivalent volumes of practically all the microphones are relatively small. Depending on the size of the

cavity used for the experiment an appropriate cartridge with a volume smaller than the cavity volume should be chosen. The equivalent circuit can therefore be further modified as shown in Fig.8 as well as the corresponding pressure equation which becomes

$$p = M_p e \frac{C}{C_{cav}}$$

Thus the measuring microphone cartridges can be used as constant volume velocity sources for measuring the compliance C_{cav} (or equivalent volumes) of small cavities. All that is required is the measurement of pressure p by another microphone, since the rest of the parameters are given on the calibration chart.

b) Acoustical load purely resistive

In cases where the resistive load R_L is much lower than $|1/j\omega C_a|$, it can be seen from eq.(2) that the sound pressure generated would be given by

$$p = M_p e j\omega C R_L$$

The sound pressure in this case increases with frequency at 20 dB/decade.

c) Acoustical load purely inductive

An inductive load L_L applied to the microphone implies excitation of an air mass. When the acoustical impedance of the microphone $|1/j\omega C_a|$ is much higher than that of the air mass $|j\omega L_L|$, it can be seen from eq.(2) that the sound pressure generated would be given by

$$p = -M_p e C \omega^2 L_L$$

The sound pressure increases with frequency at 40 dB/decade. It should be remembered that as M_p is negative the pressure developed will be in phase with the voltage applied in contrast to case a) where the pressure is developed in a cavity.

An Example of the Use of a Microphone as a Transmitter

An example of the use of a microphone as a transmitter under free-field conditions, has been described in B & K Technical Review No. 2 — 1976. The transmitter was used for the determination of the frequency response and directional characteristics of microphones and sound level meters. As it is rather important when making these types of measurements that interference phenomena do not occur, it is imperative that the sound source is relatively small. For this reason a microphone was chosen as a transmitter.

In the following, an example illustrates the use of a microphone as a transmitter under pressure conditions. It was desired to measure the acoustical resistance of a fibre material that is used for damping in the construction of an acoustical transducer. The method could also be used for measuring the resistance of sintered acoustical resistors.

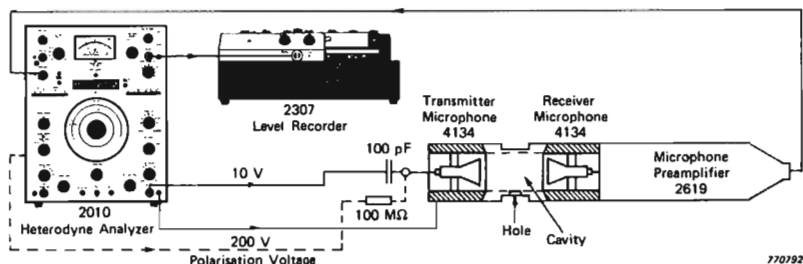

Fig.9. Measuring Arrangement for determination of the acoustical resistance of fibre strip

The measuring arrangement used is shown in Fig.9. Two microphones were fixed at the ends of a cylindrical cavity enclosing a volume of 600 mm^3 . A hole of 5 mm diameter was drilled in the side of the cavity wall which could be covered with the fibre strip when measuring its acoustical resistance. A Heterodyne Analyzer Type 2010 was used as a generator and an analyzer, which could also supply a polarization voltage of 200V to the transmitter microphone through a $100 \text{ M}\Omega$ resistor. An AC voltage of 10V was applied through a 100 pF capacitor to excite the transmitting microphone. The signal from the receiver microphone was fed to the analyzer section of the Heterodyne Analyzer and hence to a Level Recorder Type 2307. Fig.10 shows an equivalent circuit for the measuring set-up where the transmitting microphone acts as a constant volume velocity source. The equivalent volumes of the

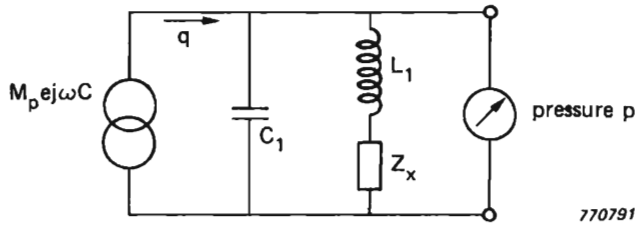

Fig.10. Equivalent circuit of the acoustic system

transmitting and receiving microphones of $2 \times 10 \text{ mm}^3$ can be neglected in comparison with the cavity volume of 600 mm^3 the compliance of which can be calculated from

$$C_1 = \frac{V_1}{\gamma P_a} = \frac{0,6 \times 10^{-6}}{1,4 \times 1,013 \times 10^5} = 4,2 \times 10^{-12} \text{ m}^5/\text{N}$$

The acoustical current $M_p e^{j\omega C}$ fed by the constant volume velocity source flows partly into this compliance and partly through the hole in the wall of the cavity which acts as an acoustical mass and can be represented by a self inductance L_1 . When the fibre material strip is placed on the hole, the air flow through the hole also has to pass through the strip. Therefore the impedance of the strip Z_x which is unknown, is connected in series with L_1 . Finally, the receiver microphone measures the pressure across the two branches of the parallel connection.

In Fig.11 four transfer functions are shown. The one marked A is obtained when the hole is completely blocked, implying that no current flows through the branch with L_1 and Z_x . Thus only the impedance of the cavity is measured. The curve should theoretically be flat, however, the slight slope implies that the process is not purely adiabatic and that some leakage might be present. Since C_1 is known, its impedance can be calculated, for example, at 300 Hz, and can be used for calibration of the set-up.

$$X_{C_1} = \frac{1}{j 2\pi 300 4,2 \times 10^{-12}} = 127 \times 10^6 \text{ Ns/m}^5$$

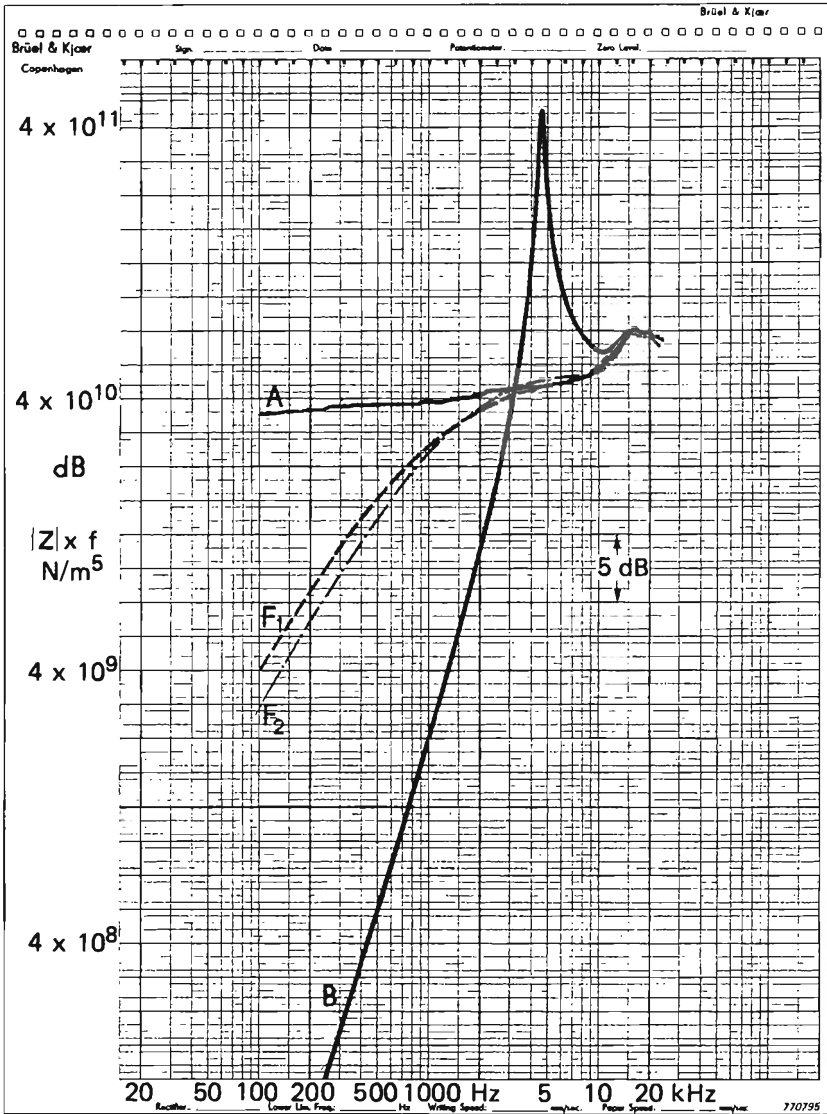

Fig.11. Transfer Function of the acoustic system

The Y axis of Fig.11 is calibrated, however, in units of $|Z|f$ (N/m^5) since the input acoustic current increases proportionally with frequency.

Curve B in Fig.11 is obtained with the hole completely open, implying that Z_X is short circuited. At 300 Hz the impedance of the parallel circuit is seen to be much lower than that for curve A indicating that the acoustic current now flows mainly through the branch with L_1 . Using the value of the impedance from curve B at 300 Hz the value of L_1 can be calculated from

$$L_1 = \frac{Z}{j\omega} = \frac{Z \times f}{2\pi f^2} = \frac{200 \times 10^6}{2\pi \cdot 300^2} = 354 \text{ kg/m}^4$$

As a check on the values of C_1 and L_1 the resonance frequency of the parallel arrangement can be calculated from

$$f_o = \frac{1}{2\pi\sqrt{L_1 C_1}} = 4128 \text{ Hz}$$

which can be seen to agree reasonably well with the resonance peak of curve B.

The fibre strip was now placed on the hole and the transfer function obtained. The curves F_1 and F_2 are for two positions on the strip. The values of the acoustical damping R_1 and R_2 are found to be $40,4 \times 10^6$ and $31,7 \times 10^6$ Ns/m^5 respectively. The slope of these curves at 300 Hz being 20 dB/decade indicates that the impedance of the fibre strip is mainly resistive.

From Fig.11 it can be seen that as there is a large difference in the impedance at 300 Hz when the hole is open and when it is closed, the fibre strip impedance will determine the total circuit impedance over a wide impedance range. Also the frequency range can be extended higher by shifting the resonance to a higher frequency. This can be achieved either by making the volume of the cavity smaller thus reducing the compliance or by making the hole in the cavity wall larger and thereby reducing the acoustical mass. The second resonance at 15000 Hz in Fig.11 is due to the longitudinal resonance of the cavity at quarter wavelength.

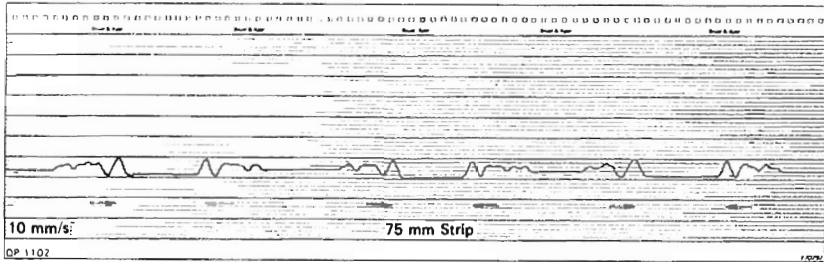

Fig.12. Acoustic Resistance of fibre strip when slid over the hole

Fig.12 shows the variation of the acoustical resistance of the fibre strip at 200 Hz when the strip is slid forward and backward over the hole.

It should be mentioned that the aim of this example has been to show the possibilities available in this kind of acoustical investigation and not to make an elaborate description of the electrical analogy of the acoustical system.

Practical Details on Supply Voltages and Distortion

When using a microphone as a transmitter, it is important that the polarization voltage is the same, if the data given for the microphone is to be valid. The electrical terminals to the microphone can be connected as shown in Fig.13. In order to protect the microphone diaphragm from damage in case of a short circuit or arcing inside the microphone, the supply voltage source should have a high impedance seen from the microphone cartridge. The resistor and the capacitor should therefore be connected close to the cartridge to limit the capacitance seen from the cartridge.

The force acting on the diaphragm, when the electrical voltage is applied, can be calculated from

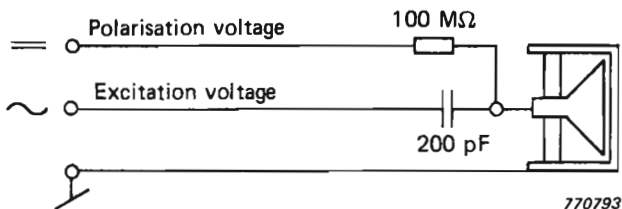

Fig.13. Electrical connections when using microphone as a transmitter

$$F = \frac{E^2 C}{2d} = \frac{E^2 \epsilon A}{2d^2}$$

where E is the voltage
 C is the capacity
 d is the distance between the plates
 A is the cross sectional area
and ϵ is the permittivity.

If the voltage supplied to the microphone has a DC and an AC component the formula can be written as

$$F = \frac{(E_o + e \sin \omega t)^2 \epsilon A}{2d^2}$$

where E_o is the DC component
and $e \sin \omega t$ is the AC component.

$$\text{i.e. } F = \frac{(E_o^2 + 2 E_o e \sin \omega t + e^2 \frac{1 - \cos 2\omega t}{2}) \epsilon A}{2d^2}$$

Thus the force has a static component

$$F_S = \frac{\epsilon A}{2d^2} (E_o^2 + \frac{e^2}{2})$$

and a dynamic component

$$F_D = \frac{\epsilon A}{2d^2} \left(2 E_o e \sin \omega t - \frac{e^2 \cos 2\omega t}{2} \right) \quad (3)$$

As regards F_S , $e^2/2$ should be small compared to E_o^2 so that the microphone sensitivity and frequency response is not affected on account of the diaphragm being displaced too far from its equilibrium position. Normally the problem will not arise if the limits in Table 2 are observed.

Microphone Type No.	4148	4125	4144 4145 4146 4160 4161 4165 4166	4133 4134 4135 4136 4138 4147 4149 4163
Maximum Limiting Voltage DC + AC peak	150	180	250	300

Table 2

Concerning F_D , the force driving the microphone, it can be seen that two components will be present in the output signal; the fundamental frequency supplied and a second harmonic distortion signal which is the dominating form of distortion in such a system. The percentage distortion of the force can be calculated from

$$D_F = \frac{e}{4 E_o} \times 100 \%$$

For determining the distortion of the system that is excited, the system's transfer function should also be considered.

From eq.(3) it can be seen that the microphone can transmit a pure sinusoidal signal if no polarization voltage is supplied ($E_o = 0$). Although in this case the acoustical signal will have a double frequency, this will not cause a problem for many applications. In fact two advantages are achieved; firstly higher sound pressure levels can be obtained without exceeding the limiting peak voltages, and secondly electrical screening problems are reduced when transmitting and receiving microphones are operated side by side.

Literature

- BRÜEL P.V. et al.: Impedance of Real and Artificial Ears. B & K Publication.
- IEC RECOMMENDATION: Publication 327. Precision method for pressure calibration of one-inch standard condenser microphones by the reciprocity technique.
- IEC RECOMMENDATION: Publication 486. Precision method for free-field calibration of one-inch standard condenser microphones by the reciprocity technique.

APPENDIX

Figure A1 shows an equivalent circuit of a reciprocal condenser microphone.

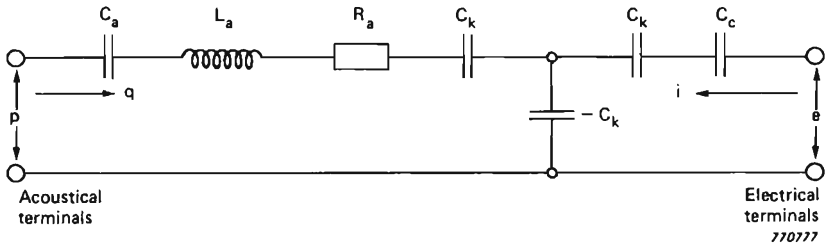

Fig.A1. Equivalent circuit of a reciprocal condenser microphone

The elements on the left side of the circuit represent the acoustical parameters, while those on the right side the electrical parameters.

C_a = acoustical compliance of diaphragm when the electrical terminals are unloaded ($i = 0$)

L_a = acoustical mass of diaphragm

R_a = acoustical damping resistance of diaphragm

C_c = electrical capacitance of the microphone when the diaphragm is rigidly fixed, i.e. volume velocity $q = 0$

C_k = compliance due to the electroacoustical coupling in the transducer

q = volume velocity through diaphragm, i.e. acoustic current

i = electrical current through electrical terminals

p = pressure across acoustical terminals (on the outside of the diaphragm)

e = voltage across electrical terminals.

If the units of the electrical and acoustical elements conform to one and the same system, e.g. the SI system, the elements can be directly used for mathematical or electrical analysis of the system.

For the microphone circuit shown in Fig.A1 the following equations can be written

$$e = - \frac{1}{j\omega C_k} q + \frac{1}{j\omega C_c} i$$

$$p = Z_a q - \frac{1}{j\omega C_k} i$$

where

$$Z_a = \left(\frac{1}{j\omega C_a} + j\omega L_a + R_a \right)$$

The open circuit pressure sensitivity (i.e. when $i = 0$) may be determined from

$$M_p (i=0) = \frac{e}{p} = - \frac{\frac{1}{j\omega C_k}}{Z_a} \quad (1)$$

At frequencies somewhat lower than the resonance frequency of the diaphragm the impedance of the acoustical mass $j\omega L_a$ and the acoustical damping R_a of the diaphragm would be negligible compared with the impedance of the compliance of the diaphragm $1/j\omega C_a$. The equivalent circuit can therefore be simplified to that shown in Fig.A2 where L_a and R_a are omitted. Equation (1) can correspondingly, be modified to

$$M_p (i=0) = - \frac{\frac{1}{j\omega C_k}}{\frac{1}{j\omega C_a}} = - \frac{C_a}{C_k}$$

M_p becomes a real number at low frequencies and is quoted on the calibration chart of each individual microphone.

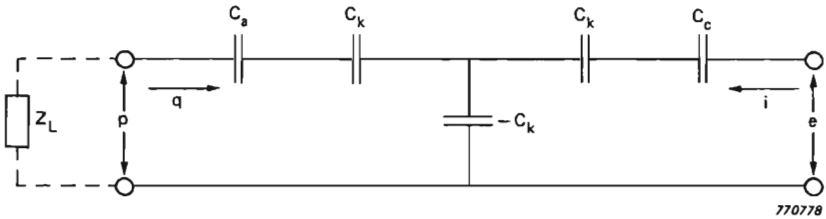

Fig.A2. Equivalent circuit of microphone for frequencies lower than the resonance frequency of the diaphragm

If a current i is now applied to the electrical terminals, a pressure is developed across the acoustical load impedance Z_L connected at the acoustical terminals, (i.e. the loading on the outside of the diaphragm). The pressure developed across " $-C_k$ ", the electroacoustic coupling element would be $-i/j\omega C_k$ and hence the pressure developed across the load impedance Z_L would be given by

$$p = -\frac{i}{j\omega C_k} \frac{Z_L}{\frac{1}{j\omega C_a} + Z_L}$$

Multiplying the numerator and denominator by $j\omega C_a$ and substituting $M_p = -C_a/C_k$ we obtain

$$p = M_p i \frac{\frac{1}{j\omega C_a} Z_L}{\frac{1}{j\omega C_a} + Z_L} \quad (2)$$

For practical reasons the current i fed to the electrical terminals can be substituted by the voltage e applied, and the cartridge impedance. As the load impedance Z_L is normally much lower than $1/j\omega C_a$ its influence on the electrical input impedance can be neglected. The total impedance can then be represented by the capacitance

$$C = \frac{C_c}{1 + \frac{C_c}{C_k} M_p}$$

It should be noted that although M_p is given as a positive number on the calibration chart, it is a negative number; therefore C becomes larger than C_c and is equal to the polarized capacity quoted on the calibration chart. Thus equation (2) can be written as

$$p = M_p e^{j\omega C} \frac{\frac{1}{j\omega C_a} Z_L}{\frac{1}{j\omega C_a} + Z_L} \quad (3)$$

From equation (3) it can be seen that the product $M_p e^{j\omega C}$ represents the volume velocity fed to the two impedances connected in parallel, namely the load impedance Z_L and the diaphragm impedance $1/j\omega C_a$.

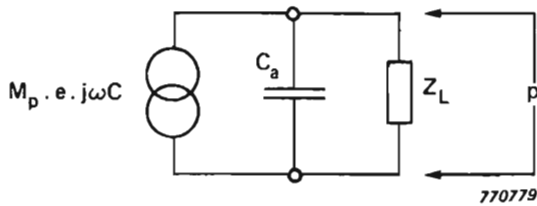
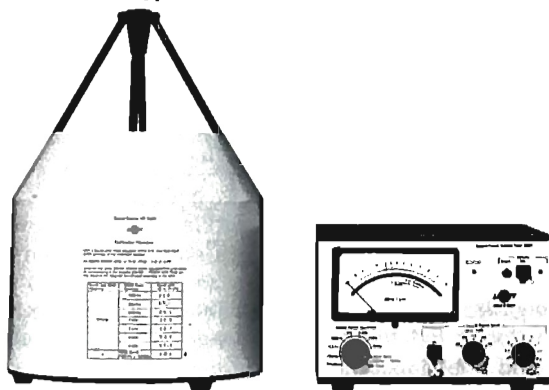

Fig.A3. Simplified equivalent circuit of microphone

The equivalent circuit diagram, Fig.A3, can therefore be drawn where p is the pressure generated across the load impedance.

News from the Factory

Sound Power Source Type 4205



The sound power emitted by machinery and equipment can be conveniently determined using the substitution method or the juxtaposition method, when facilities such as an anechoic room or a Reverberation chamber are not available. For these methods a calibrated sound power source such as Type 4205 is required, the acoustic power output of which is continuously variable.

The methods basically involve the following procedure. The sound level (in dB(A)) of the test object is measured at a certain position using a sound level meter. The test object is then removed and substituted by the 4205. The sound power output of the 4205 is adjusted until the same sound level reading is obtained on the sound level meter placed at the same position. The sound power output of the 4205 can then be read directly from the built-in meter display. If the test object cannot be switched off or removed, the sound source is placed beside the test object and its sound power output is adjusted until the reading on the sound level meter is 3 dB higher than the value obtained when the test object was operating alone. The sound power output from the 4205 is then equal to that emitted by the test object and can be read off the meter display.

If the sound power output of the test object is desired in 1/1 octaves, the 4205 can be made to emit sound power in octave bands, using the seven built-in 1/1 octave filters with centre frequencies from 125 Hz to 8 kHz. In this case the sound pressure level measured should also be filtered in respective octave bands, a task that can be conveniently performed by the analyzing Sound Level Meter Type 2215.

The Sound Power Source Type 4205, which consists of two units, a sound source HP 1001 containing two loudspeakers, and a small, battery operated noise generator, is capable of giving a continuously variable acoustic power output between 40 and 100 dB re. 1 pW. The output may be wide band pink noise in the frequency range 100 Hz to 10 kHz or octave band filtered noise.

The 4205, together with the Level Recorder Type 2306 and the Sound Level Meter Type 2215, forms a convenient set of battery operated instruments for building acoustics measurements such as reverberation time, sound absorption, sound transmission and sound distribution. The efficiency of loudspeakers, i.e. the ratio of acoustic power output to the electrical power input can also be measured.

•Third Octave and Octave Band Filter Sets Types 1617 and 1618



Third octave and octave band filter sets are key links in any instrumentation chain for the frequency analysis of acoustic, electro-acoustic, building acoustic or vibration signals. The filter characteristics of the filter sets Types 1617 and 1618 fulfil the strictest requirements laid down by IEC, DIN and ANSI standards for third octave and octave band filters. In these new filter sets several novel features have been incorporated, such as electronic switching via a built-in digital controller, digital identification of centre frequency and bandwidth, availability of overlapping octave bands and choice of floating or grounded input.

Type 1618 is the basic type having filter band centre frequencies from 2 Hz to 20 kHz. Its frequency range can be divided either into 41 third octave bands or 41 overlapping octave bands. An A weighting network is included as well as an overload indicator for the input section. The digital controller can step the filters on external command from a Level Recorder Type 2306 or 2307.

Type 1617 has third octave filter bands extending up to 160 kHz centre frequency and in addition has B, C and D weighting networks. Filter scanning can be controlled by a Level Recorder and there is a built-in IEC interface to permit direct control by other instruments and systems using this standard. The IEC interface permits the filter centre frequency, bandwidth (1/3 or 1/1 octave) and averaging times to be varied in an arbitrary sequence according to any particular measuring program. A DC ramp output is also available to control the X axis of an X—Y recorder.

A key feature of the 1617 is that it can control the averaging times of the Measuring Amplifier Type 2607 or of the Frequency Analyzer Type 2120 according to nine preset programs to maintain a nearly constant BT product for constant confidence levels.

Precision Sound Level Meter and Octave Analyzer Type 2215



The Precision Sound Level Meter and Octave Analyzer Type 2215 employs modern miniaturisation techniques to obtain a compact instrument for virtual one-hand operation. It incorporates A, C and Lin. weighting networks and a set of 10 octave filters with centre frequencies between 31,5 Hz and 16 kHz.

The sound level meter fulfils the requirements of IEC 179, DIN 45633 part 1 and ANSI 1.4—1971 Type S1, while the built-in filters fulfil the strictest requirements laid down for octave filters by IEC, DIN and ANSI standards.

The 2215 is equipped with a half-inch Condenser Microphone Type 4165, which gives it a frequency range from 20 Hz to 20 kHz and a dynamic range from 26 to 140 dB(A). To aid direct reading of sound level and frequency, the attenuator setting and the filter centre frequency are displayed in windows on the meter scale. The meter indicates true RMS, without approximation, on a large easy-to-read 30 dB linear scale. There is an overload indicator, and a push button attenuator gives a fast, convenient 10 dB shift of the meter range. Linear 60 dB DC output and AC output are available for level recorders. With the use of cable AQ 0147 the portable Level Recorder Type 2306 can be remotely controlled for semi-automatic analysis.

Power to the sound level meter is fed from four 1,5 V batteries (IEC type R6) and is automatically switched off when the battery output falls below the minimum usable voltage, to prevent incorrect readings. On account of the simplified operating procedures of the 2215, inexperienced personnel could use the instrument after a minimum of training. The 2215 will find wide applications in the fields of industrial noise control, architectural acoustics, hearing conservation programmes, product quality control, and audiometer calibration.

Waveform Retriever Type 6302

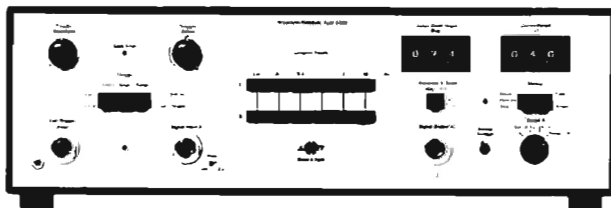

An oscilloscope trace of a vibration signal from intricate machinery usually displays some fundamental signal components buried in a fog of harmonics and noise, and is therefore of limited practical use.

With the use of the Waveform Retriever Type 6302 it is possible to extract the basic periodic signal with as many harmonics as desired (up to 180) and to plot the waveform as a function of time on a level recorder. This enables the engineer to examine the dynamic behaviour of machine parts through each phase of their cycle and identify irregularities caused by, for example, faulty gear teeth, an unbalanced fan blade, or a tight point in a bearing. Thus regular plots from a machine can give indication of deterioration or possible failure points. The two inputs of the instrument enable two signals to be processed simultaneously to determine differences between their amplitudes and phases.

The Waveform Retriever accepts practically any waveform in the frequency range DC to 10 kHz with signal levels up to $\pm 7,5$ V peak. Triggering is possible on the positive or negative slopes of external trigger signals of 50 mV to 20 Vp-p. The angular resolution is 1° and the plotted waveform can be made to start at any angle in the cycle. The time for one sweep period can be chosen between 1 s (for low frequencies or very quick, rough, plotting) and 999 s (for maximum definition).

Each channel contains a variable low pass filter to exclude frequencies away from the immediate vicinity of the frequency of interest (and its harmonics) from being examined, Cut-off frequencies are adjustable to 0,1, 0,3, 1, 3, and 10 Hz. A DC ramp output provides synchronization with Level Recorder Type 2307, while a pulse output controls synchronization of Level Recorder Type 2306.

The time domain analysis performed by 6302 will be a valuable alternative or supplement to the familiar frequency analysis.

PREVIOUSLY ISSUED NUMBERS OF BRÜEL & KJÆR TECHNICAL REVIEW

(Continued from cover page 2)

- 2-1974 On Signal/Noise Ratio of Tape Recorders.
On the Operating Performance of the Tape Recorder
Type 7003 in a Vibrating Environment.
- 1-1974 Measurements of averaging times of Level Recorders
Types 2305 and 2307.
A simple Equipment for direct Measurement of Reverberation
Time using Level Recorder Type 2305.
Influence of Sunbeams striking the Diaphragms of Measuring
Microphones.
- 4-1973 Laboratory tests of the Dynamic Performance
of a Turbocharger Rotor-Bearing System.
Measurements on the Resonance Frequencies of
a Turbocharger Rotor.
- 3-1973 Sources of Error in Noise Dose Measurements.
Infrasonic Measurements.
Determination of Resonance Frequencies of Blades and
Disc of a Compressor Impeller.

SPECIAL TECHNICAL LITERATURE

As shown on the back cover page Brüel & Kjær publish a variety of technical literature which can be obtained free of charge.

The following literature is presently available:

Mechanical Vibration and Shock Measurements

(English, German, Russian)

Acoustic Noise Measurements (English, Russian), 2. edition

Strain Measurements

Architectural Acoustics (English)

Standards, formulae and charts (English)

Catalogs (several languages)

Product Data Sheets (English, German, French, Russian)

Furthermore, back copies of the Technical Review can be supplied as shown in the list above. Older issues may be obtained provided they are still in stock.

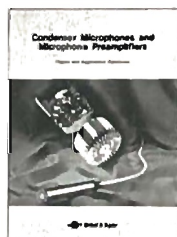
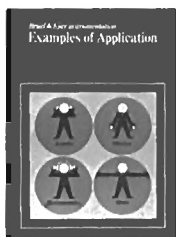

Brüel & Kjær

DK-2850 NÆRUM, DENMARK · Telephone: + 45 2 80 05 00 · Telex: 37316 bruka dk